

GENIUS: ARETHA Lighting

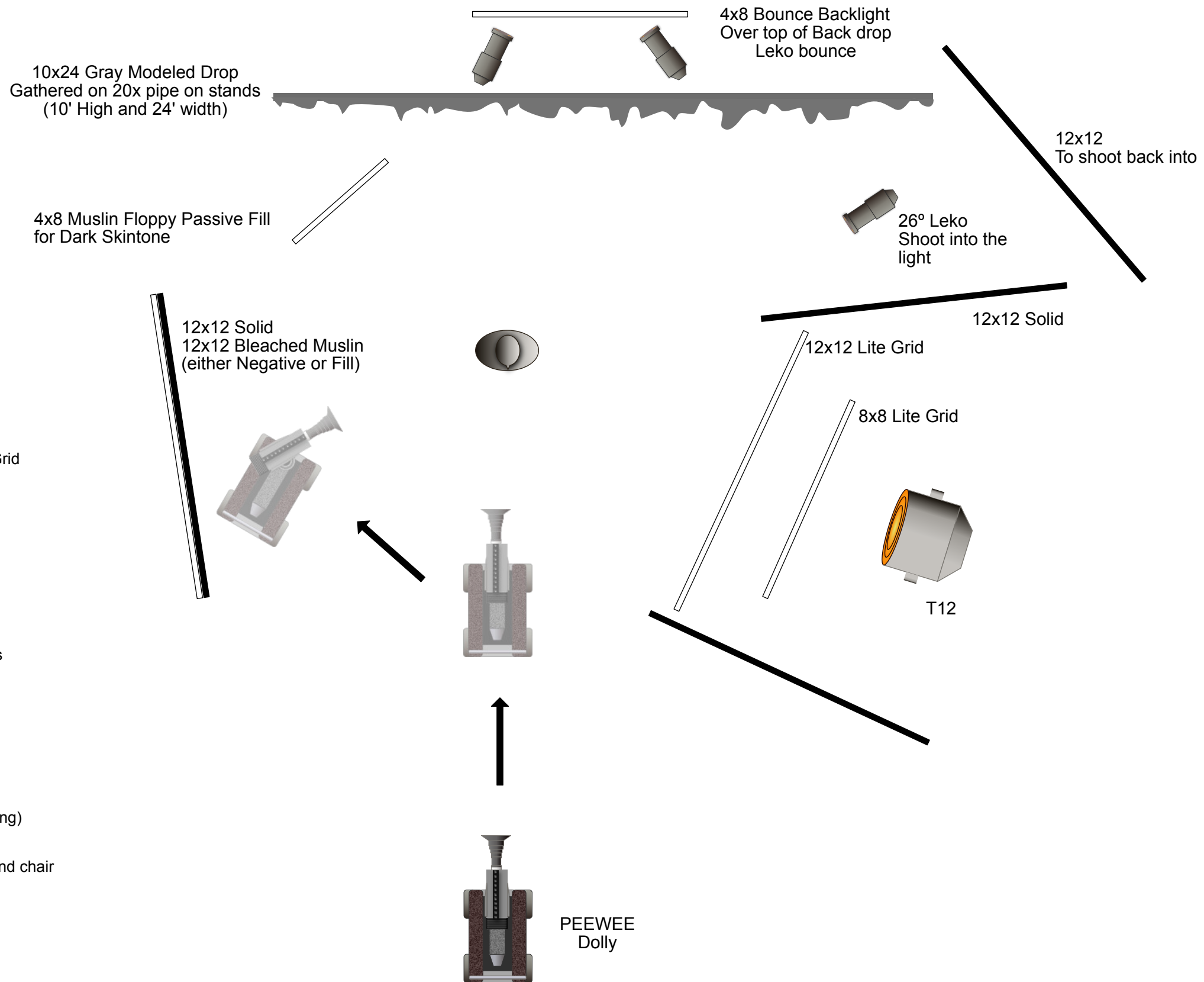



Additional Lighting-

- On a goal Post to roll in
FreeStyle 41 thru 4x Full Grid
- S60 Skypanel
- 3-4' Quasars
- 3-2' Quasars
- 4 Open face Redheads
- 3 Additional Lekos
- Dimmers for 1K's

- 4x4 Unbleached Muslin
- unbleached Muslin scraps
- 4x Beadboard
- 2x Beadboard
- 20X Solid (to shoot into Flashes)

- Props-
- 4-Flashbars
 - 2-Table Lamps and table
 - Standing Floor Lamp
 - Desk
 - Desk Lamp
 - Piano
 - Microphone on Stand (Performing)
 - Cigarettes
 - Aretha's Sunglasses
 - Lighted Makeup Mirror/Vanity and chair



CAMERA TEST LIGHTING DIAGRAM

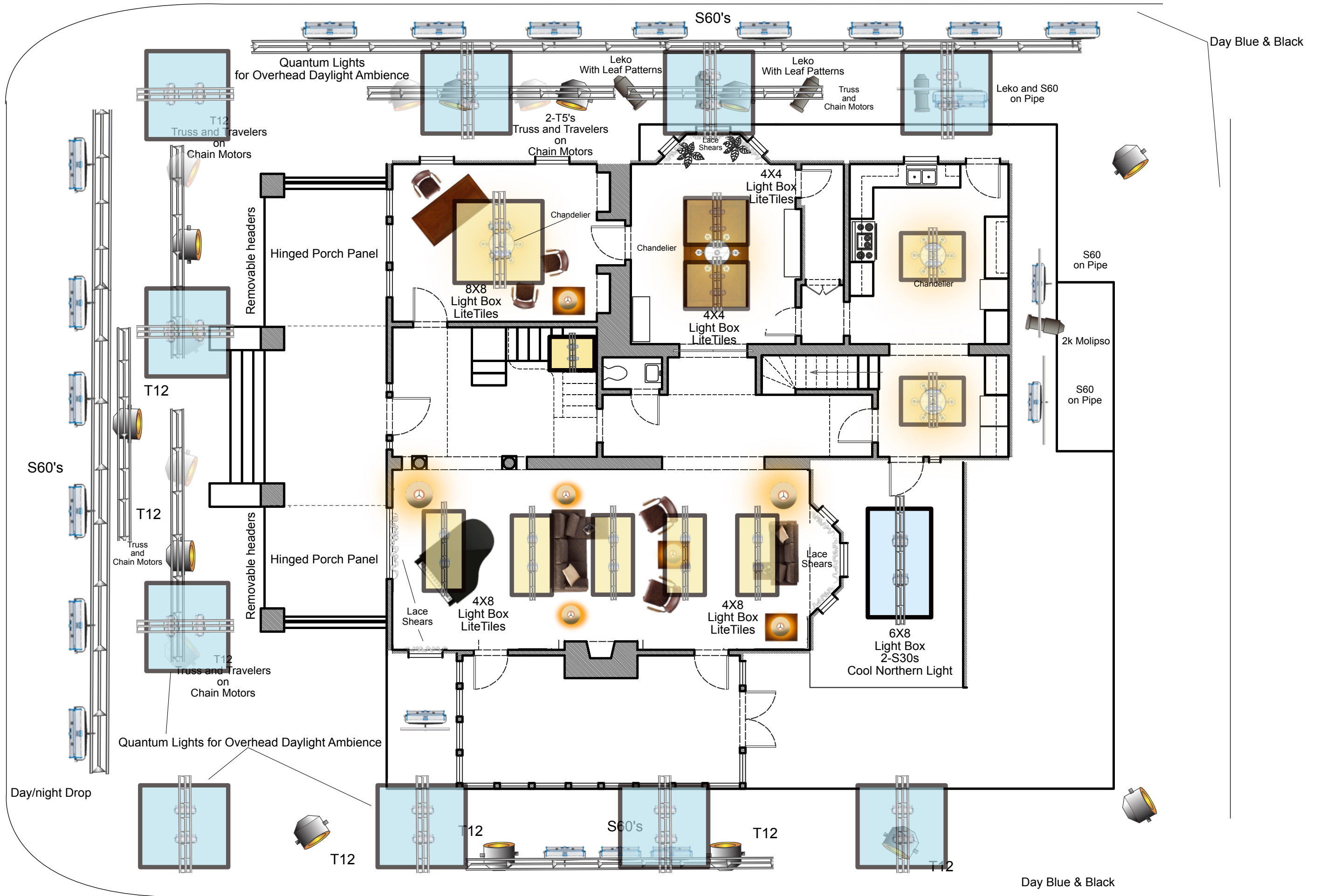

Franklin Home 1st Floor



NOTE: SCENE # 30 IS PRIORITY INTERIOR
360° REQUIRES MORNING LIGHT
(9:00AM-12:30)

-Shooting Kids first means shooting
Kids out within 5 hr. window
-Means jumping around to get kids
work completed first

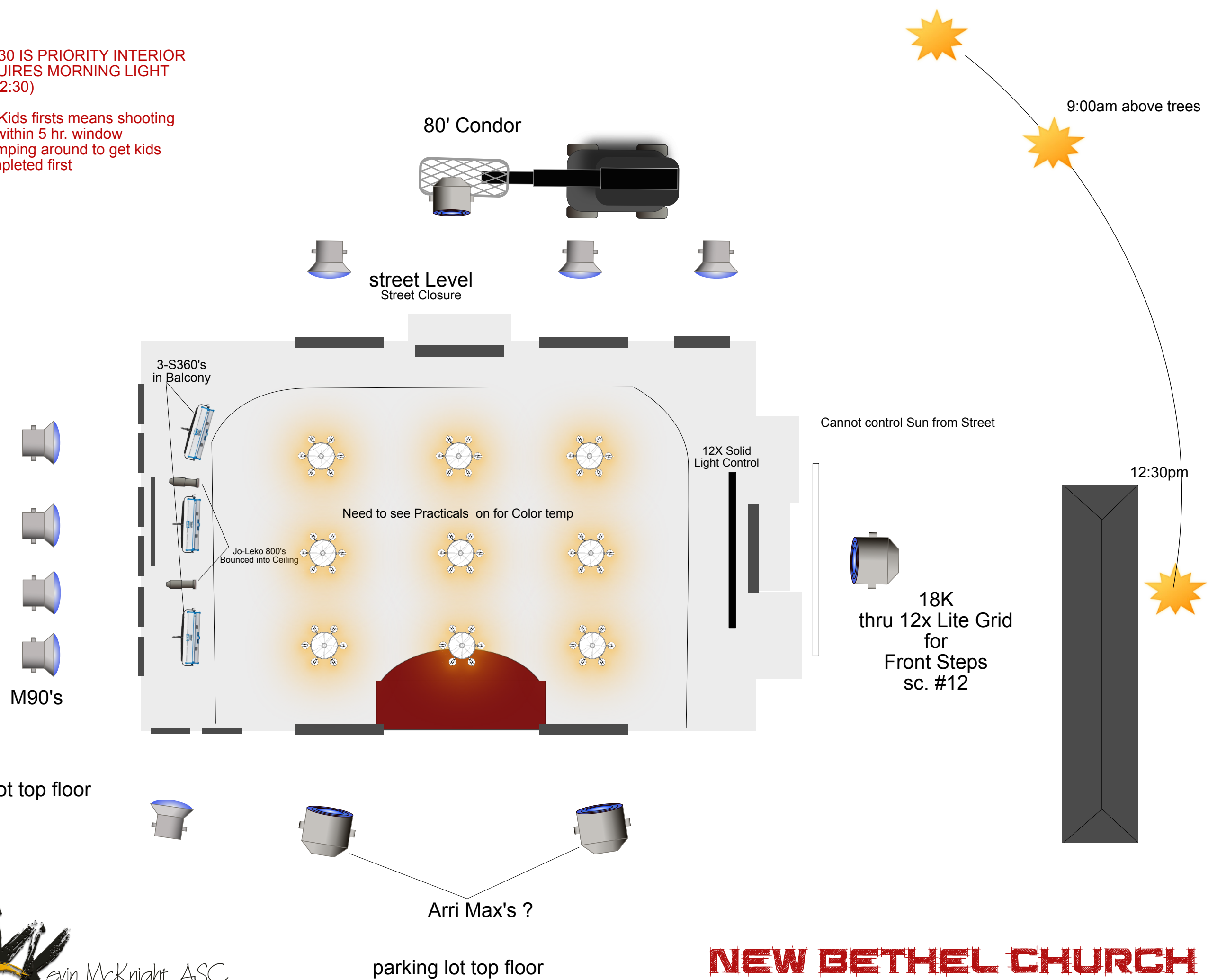

NEW BETHEL CHURCH EXT. LIGHTING DIAGRAM

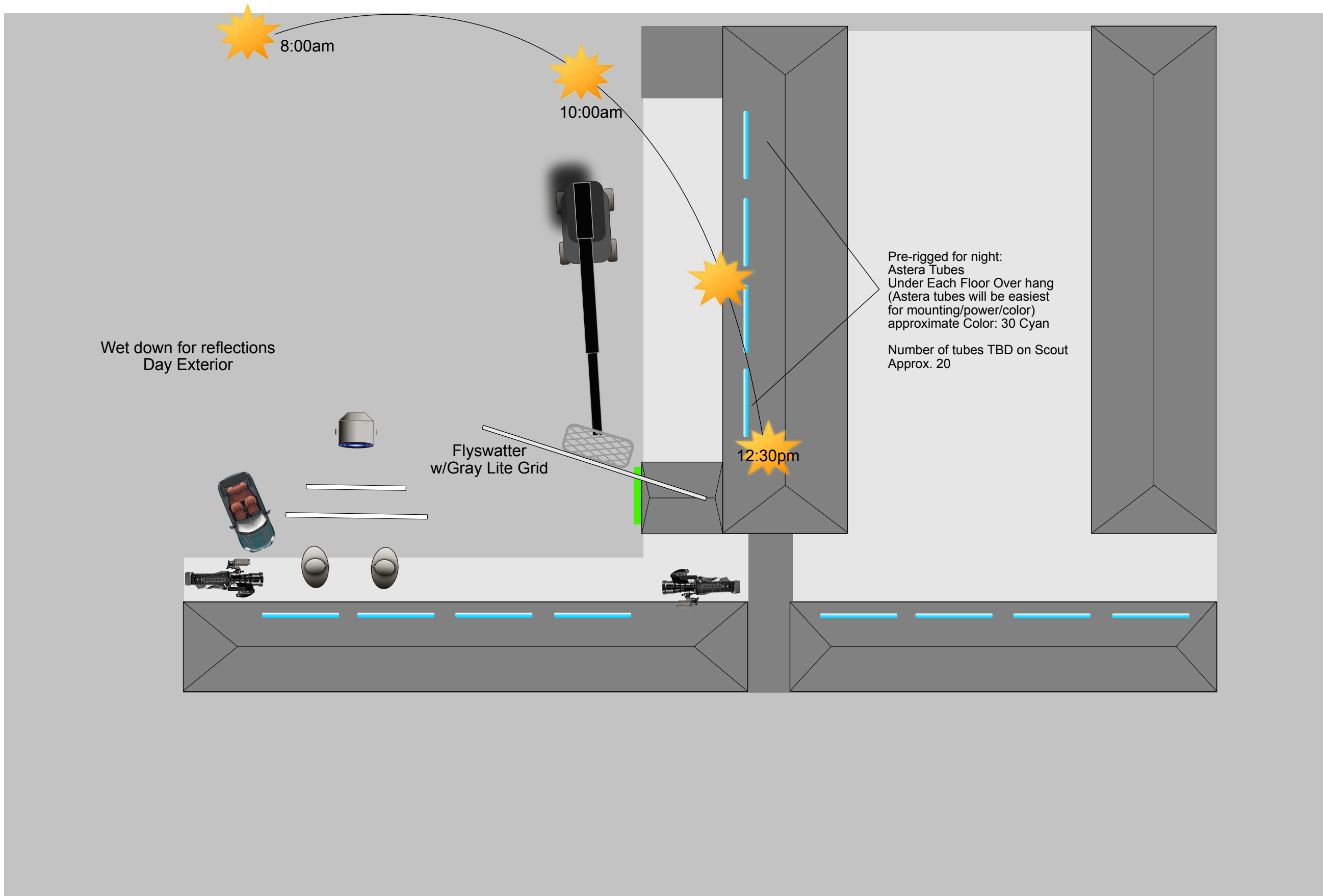

S360 thru 8x Lite Grid (moonbox)
80' Condor (Color:Peacock Blue)

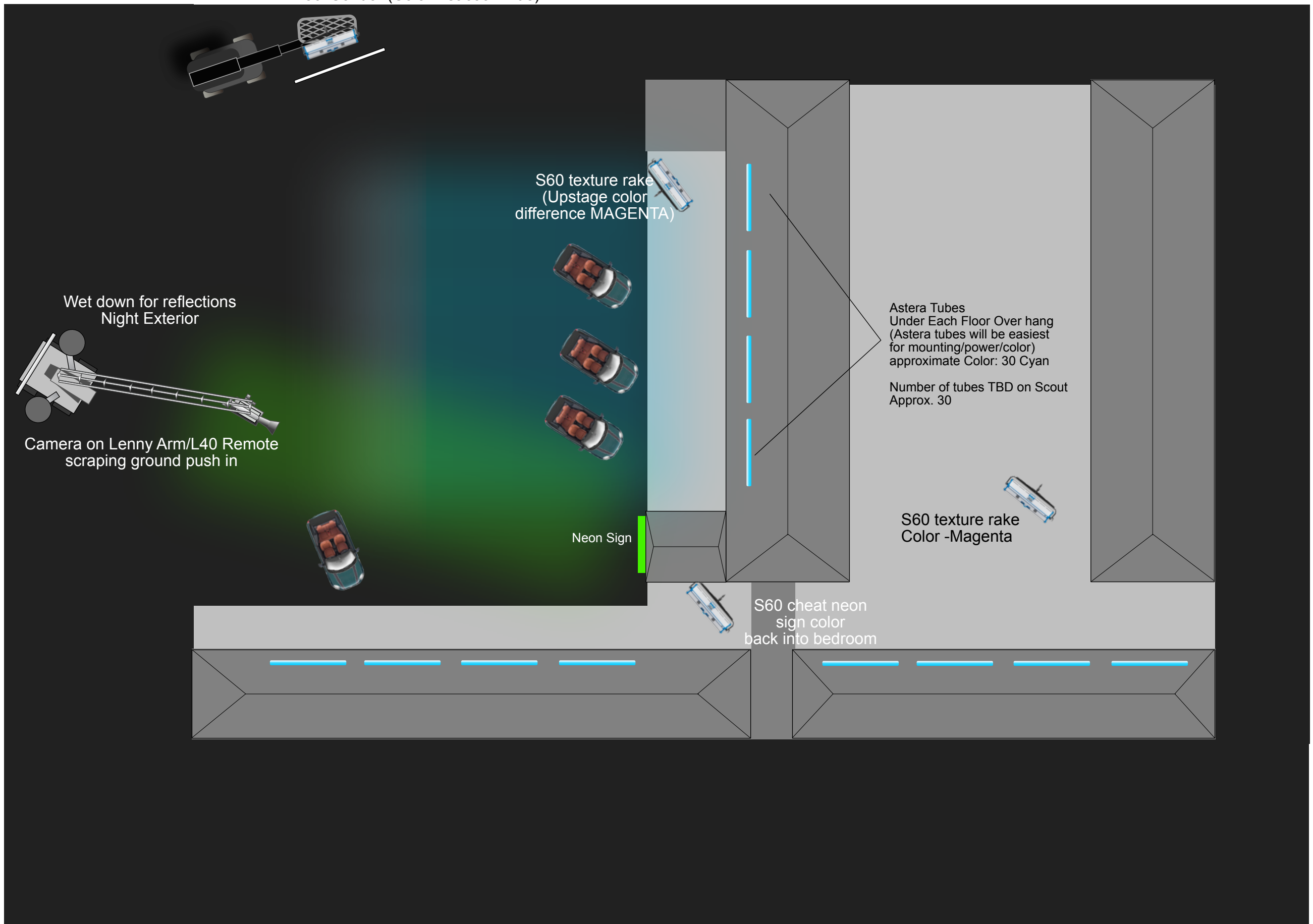

Hotel Night Exterior

Scene # 23
Tent in for Night
for majority of scene

-will Pick up Rick's
entrance night for night

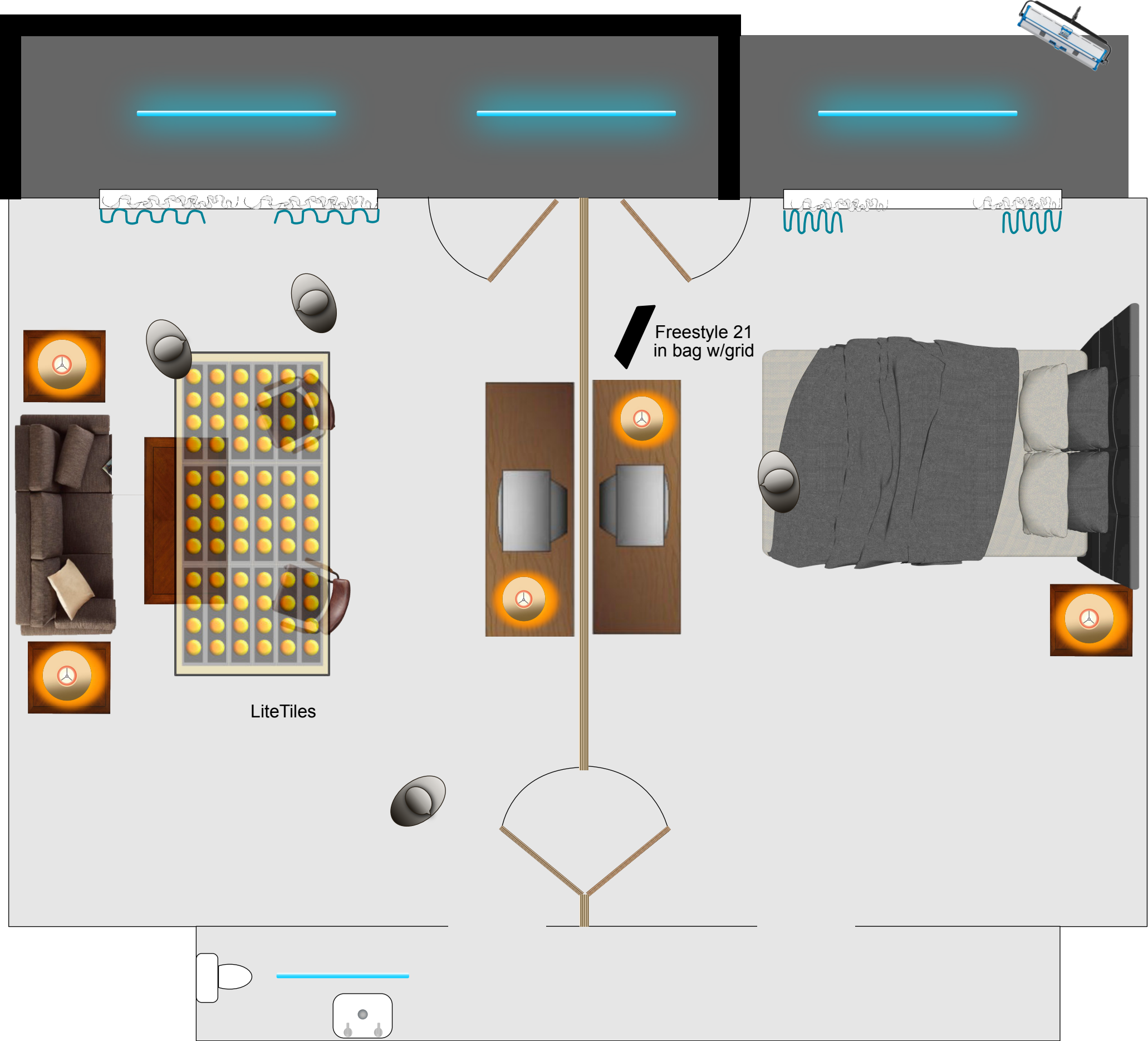

ROADSIDE HOTEL NIGHT INT. LIGHTING DIAGRAM

8' Astera top of stairs
Gradate from low on
backwall-Cyan 60

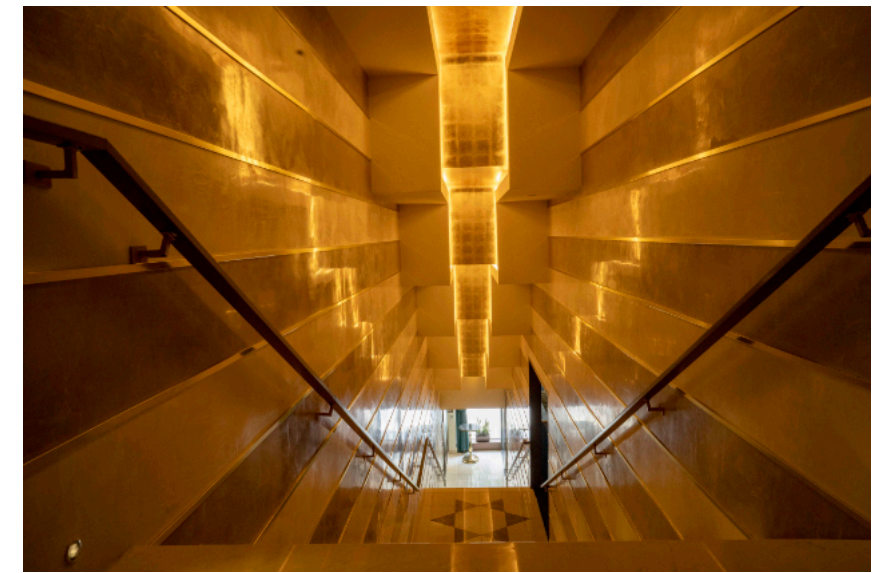

8' Astera Tubes to match
Gold color

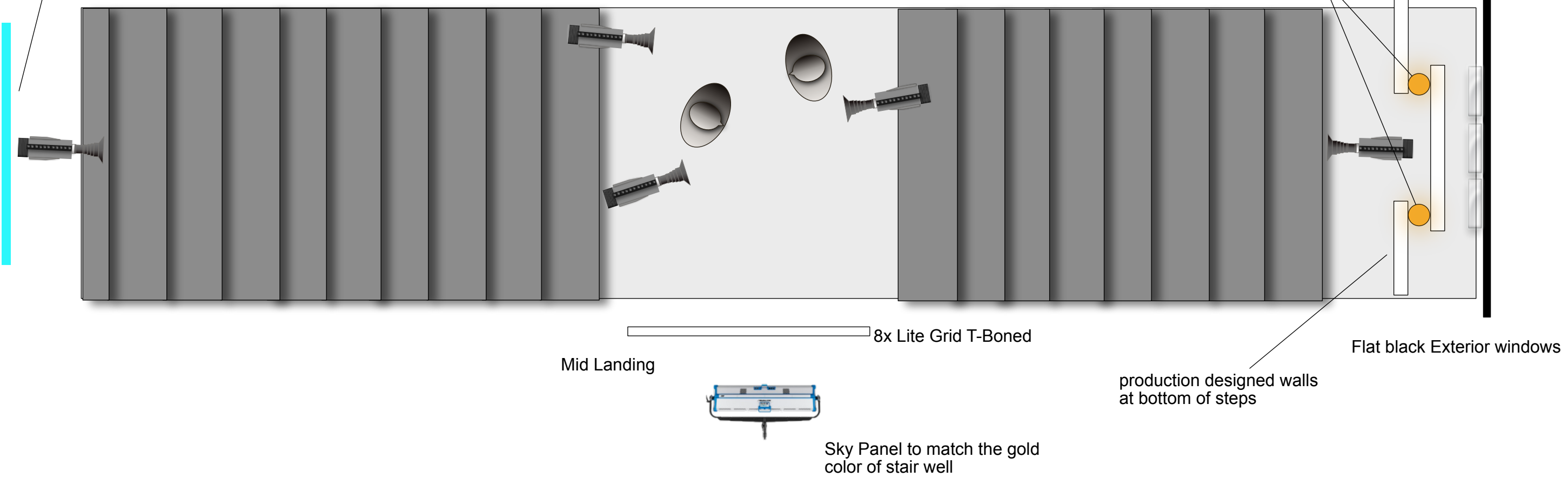

Stairwell Glynn & Aretha



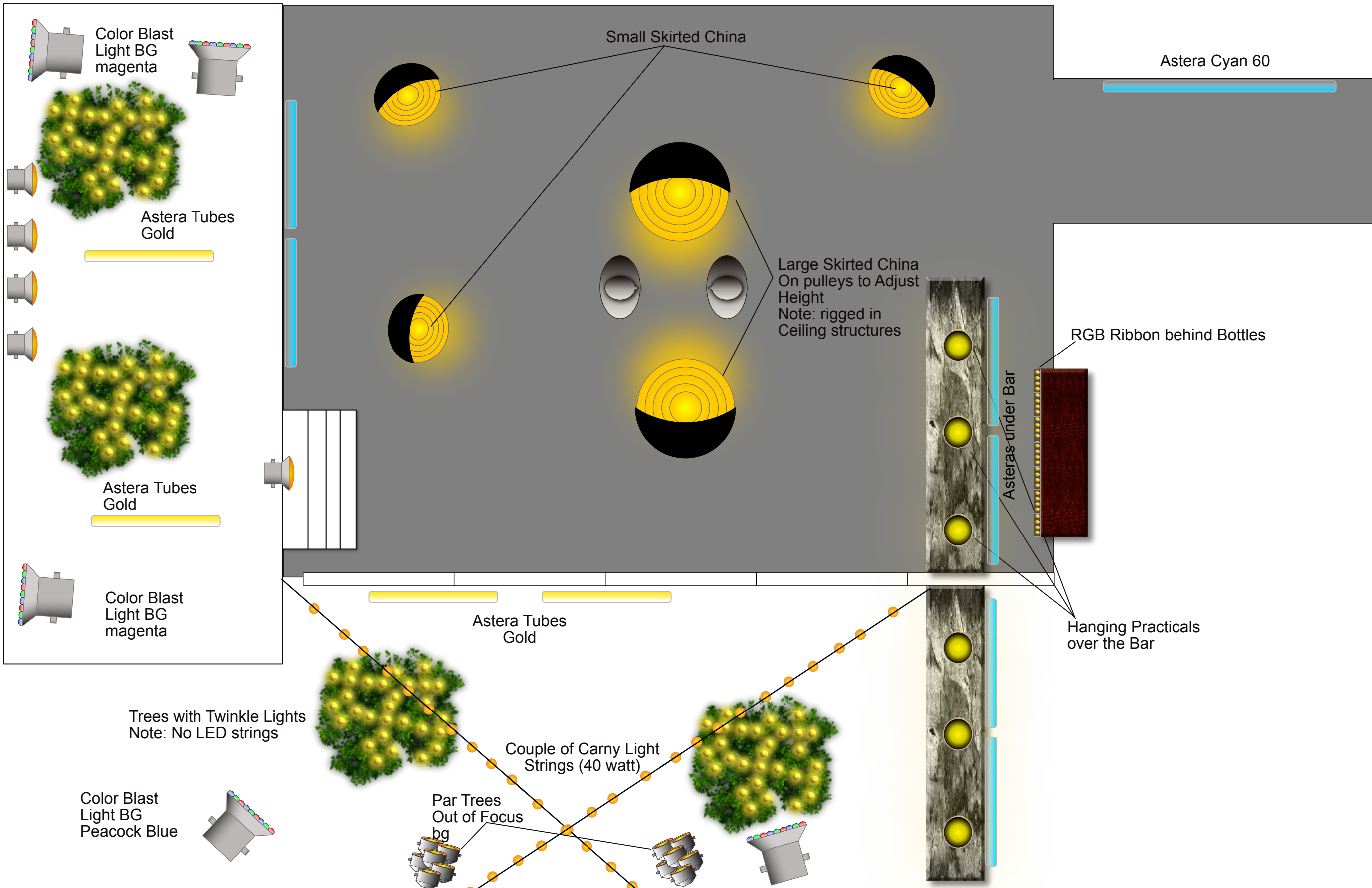

Grammy's After Party



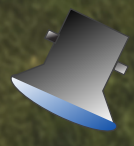

4KHMI lighting bg Trees

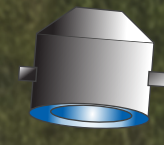

18K lighting bg atmosphere

Upside down lampshades suspended with in Carni-lights 75watt globes to be Photographed

Tables with lamps 40watt globes

Carni-light strings w/40Watt

Underwater Par

Tungsten Malibu Light Tree in Background

Quasar tubes hung in rafters per scouting

Aretha Birthday Party



CL Car Crash Night Exterior

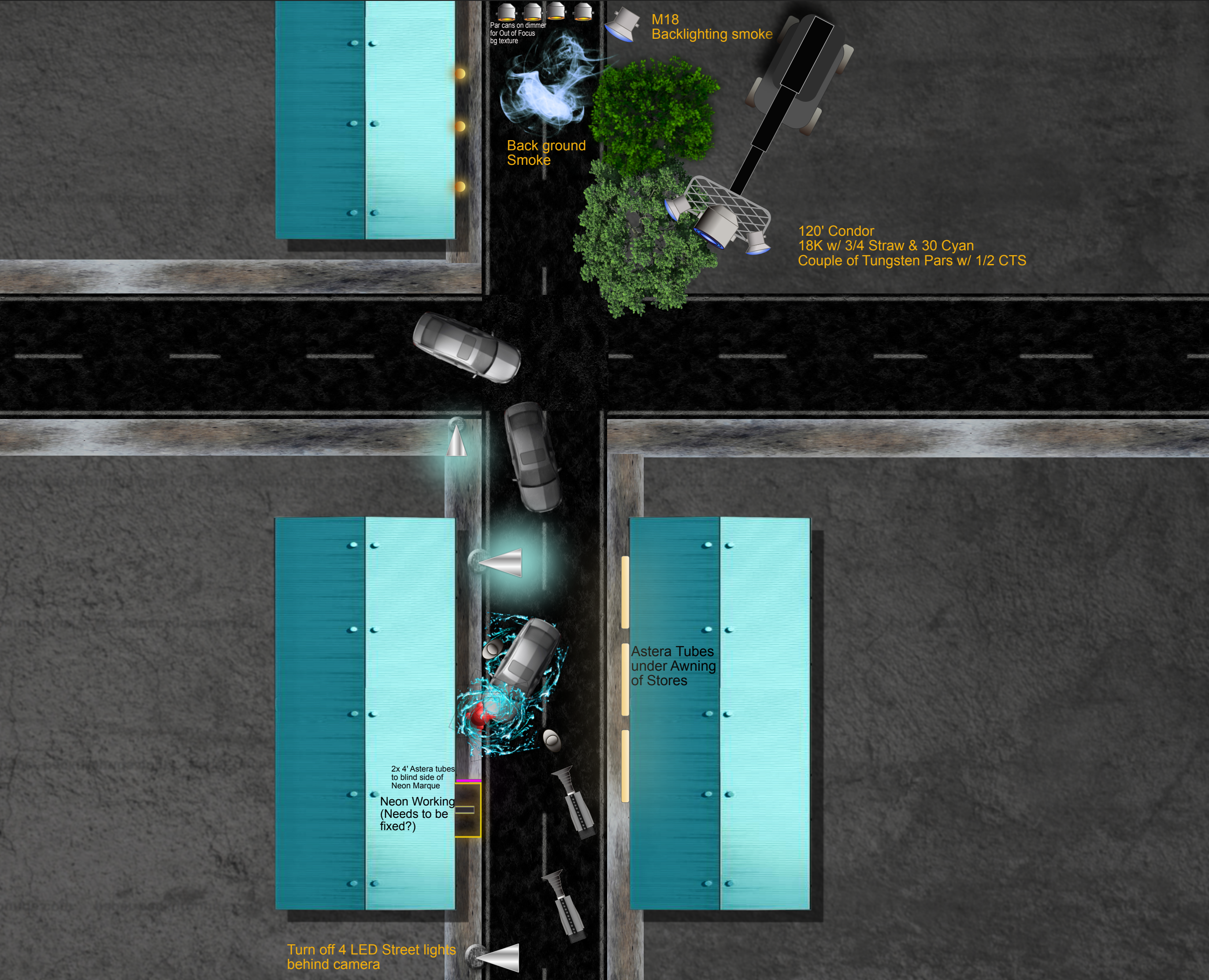

Par cans on dimmer for Out of Focus bg texture

M18 Backlighting smoke

Back ground Smoke

120' Condor
18K w/ 3/4 Straw & 30 Cyan
Couple of Tungsten Pars w/ 1/2 CTS

Astera Tubes under Awning of Stores

2x 4' Astera tubes to blind side of Neon Marque
Neon Working (Needs to be fixed?)

Turn off 4 LED Street lights behind camera